

# BRAGG GRATINGS WRITTEN IN HIGH BIREFRINGENCE OPTICAL FIBERS FOR TRANSVERSAL STRAIN SENSORS

Ilda Abe, José Luíz Fabris, Bárbara Winiarski Diesel, Meire Cristina Fugihara, Hypolito José Kalinowski<sup>•</sup>

*Centro Federal de Educação Tecnológica do Paraná, 80230-901 Curitiba, Brazil*  
*e-mail: [ildabe@cpgei.cefetpr.br](mailto:ildabe@cpgei.cefetpr.br), [fabris@cefetpr.br](mailto:fabris@cefetpr.br), [diesel@cpgei.cefetpr.br](mailto:diesel@cpgei.cefetpr.br), [meire@cpgei.cefetpr.br](mailto:meire@cpgei.cefetpr.br), [hjkalin@cpgei.cefetpr.br](mailto:hjkalin@cpgei.cefetpr.br)*

**Carmem Lúcia Barbosa**

*Instituto de Estudos Avançados, Centro Técnico Aeroespacial, 12300 São José dos Campos, Brazil*  
*e-mail: [carmi@ieav.cta.br](mailto:carmi@ieav.cta.br)*

## Abstract

Fiber Bragg gratings are written in high birefringence PANDA optical fiber, aimed to transversal stress measurements. Optical characterization, without and with transversal load applied, is presented together with numerical simulations of the optical spectra.

Fiber Optic Bragg Grating (FOBG) sensors usually have one or more Bragg grating written in a single (standard) fiber. The shift in the spectral position of the reflection band of each grating permits to determine physical measurand acting on it like, e.g., longitudinal strain or temperature. However, there are several FOBG applications (material science, composites, aircraft, biomechanics...) where the strain along all principal axis of the material are required [1], involving the experimental measurement of both the longitudinal and the transversal components of the strain. Such measurement can be done using several FOBG aligned along three perpendicular axis but the dimensions of this assembly, its influence in the material where is embedded and the associated complexity in the optical access restricts its widespread use. A single FOBG able to detect all three components of strain would be required to fulfill the experimental needs in that areas [2].

In this work we present the characterization of FOBG written in polarization preserving optical fibers. The results show that it is possible to optimize the grating parameters in order to use that grating to measure transversal strain components acting in the optical fiber.

Polarization preserving fibers (Bow-tie, Panda, elliptical core or cladding) have high birefringence, with refractive index along principal directions of the fiber structure. Modal or stress induced birefringence leads to different propagation constants for the two orthogonal polarization associated with the fundamental mode in the fiber core. The effective refractive index of each polarization mode fulfills the Bragg condition in FOBG for different wavelengths, causing a two-peak reflection spectrum, as shown in Fig. 1. Strain in the FOBG will cause additional shift in the peak positions, depending on the strain symmetry. Measurement of the spectral shift for each polarization component allows determining both components of the transversal strain.

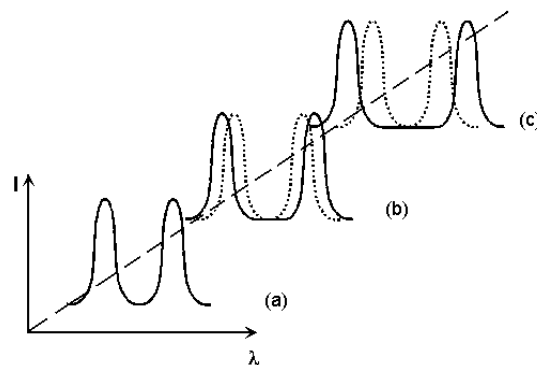

Figure 1 – (a) Schematic reflection spectrum from a FOBG in HiBi optical fiber. (b) and (c) Predicted spectral shift of each component under stress applied along two orthogonal directions (dashed line represents spectra without strain).

<sup>•</sup> Present address: Instituto de Telecomunicações – Polo de Aveiro, 3810-193 Aveiro, Portugal.  
*e-mail: [hjkalin@av.it.pt](mailto:hjkalin@av.it.pt)*

The bandwidth of a FOBG is usually defined by the full width at first zero (of the lateral side lobes) – FWFZ,  $\Delta\lambda$ , given by [3]:

$$2\Delta\lambda = \frac{\lambda^2}{\pi n_{\text{eff}} L} \sqrt{(kL)^2 + \pi^2}$$

where  $\lambda$  is the central wavelength,  $n_{\text{eff}}$  is the effective refractive index,  $k$  is the coupling constant between the forward propagating mode and the back reflected one coupled by the grating structure and  $L$  is the grating length. From that equation it can be seen that, upon the grating characteristics ( $k$ ,  $L$ ), a resolved structure can be seen in the FOBG optical spectra due to birefringence. Otherwise, usually when the product  $kL$  is high – strong coupling condition, both spectra will overlap into a single reflection band.

The FOBG used in this work are written in PANDA polarization preserving fibers. PANDA fibers have two stress applying members, formed by a glass with different composition, placed on the sides of the fiber core (see Fig. 2). When the fiber is drawn an asymmetric stress acts on the fiber core, resulting in changes in the refractive index along the two directions shown in Fig. 2, the principal directions of the birefringent refractive index profile.

We use Bragg Gratings written in this fiber, after suitable hydrogen loading to increase photo sensitivity, using a phase mask interferometer illuminated by an UV (257 nm) Argon doubled laser, in the IEAv/CTA [4]. The illumination period of the fiber during the process is in the order of a few minutes, reflecting the high efficiency of the hydrogen loading to enhance the photo sensitivity of the bare fiber.

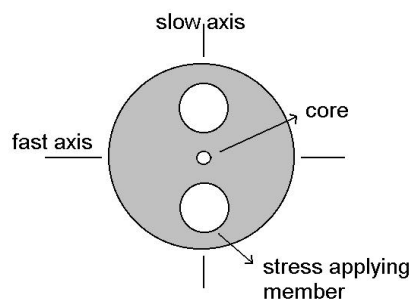

Figure 2 – PANDA fiber structure with the indicated fast and slow birefringence axis.

Fig. 3 shows the optical set-up used to characterize the obtained FOBG's. The amplified spontaneous emission (ASE) of an Erbium Doped Fiber Amplifier (EDFA) is used as broadband light source (1530-1570 nm), coupled to the FOBG through an optical coupler. Reflected light from the FOBG is fed to the Optical Spectrum Analyzer, while the unused port of the optical coupler is index matched to avoid spurious reflection from the fiber – air interface.

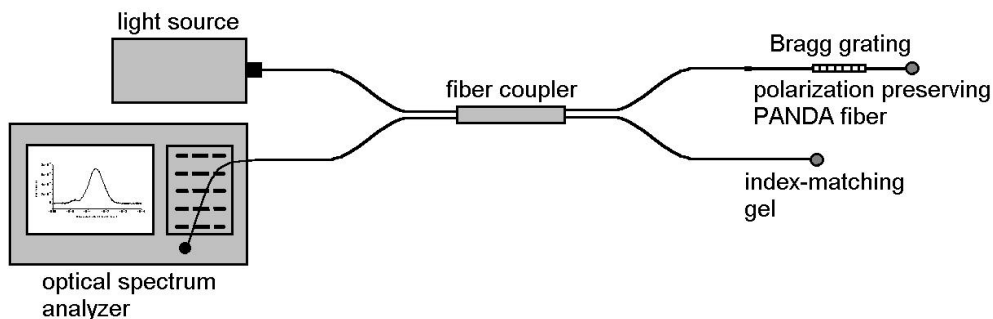

Figure 3 – Optical set – up to measure the reflection spectrum of FOBG written in HiBi fibers.

A mechanical system is used to apply transversal stress to the FOBG under study, using the assembly depicted in Fig. 4. The contact length of the optical fiber and the glass plate is 10mm.

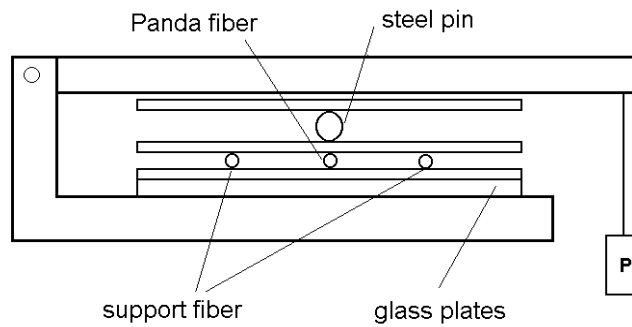

Figure 4 – Mechanical assembly to apply transversal stress on an optical fiber.

Weights of different masses (from 1 to 12 kg) are suspended in the pivoted arm of the apparatus with steps of 1 kg. The optical spectrum with no load shows a single reflection band with 1 nm bandwidth and centered at 1511,4 nm. Further measurements shows no significant variations in the optical spectra until the load reached the 6 kg mark. From that load on, a progressive splitting in the optical reflection band can be seen, as shown in Fig. 5.

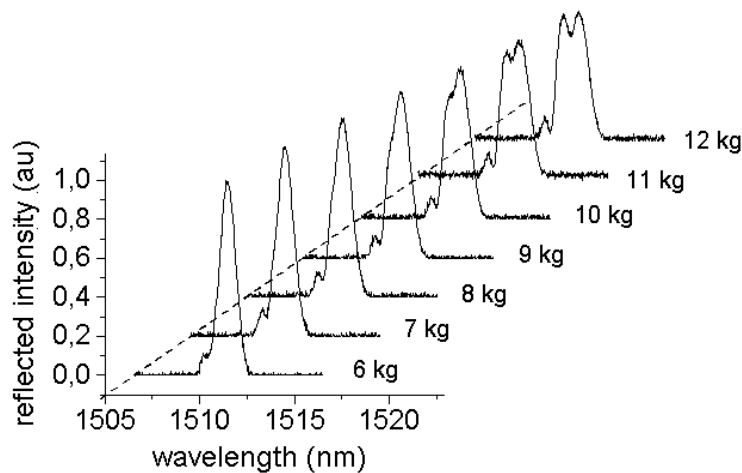

Figure 5 – Optical reflection spectra of the FOBG in PANDA fiber when subjected to transversal load.

The two peaks in the optical spectrum with applied load of 12 kg present a splitting of 0.8 nm. The length of the FOBG is in the order of 1 mm, estimated from the diameter of the laser beam spot. As the writing time is short, due to hydrogen loading and to operate in a wavelength close to the maximum of the absorption band associated to the Ge defects linked to photo sensitivity in optical fibers, we also estimate that the coupling coefficient,  $k$ , should be high. Both mentioned factors lead to broad, non-resolved reflection bands due to birefringence. The applied stress induces an extra birefringence, and permits to partially resolve the spectra due to two orthogonal polarizations.

Coupled mode theory and transfer matrix methods, available from IFO Grating (Optiwave) software, are used to numerically simulate the FOBG spectra in HiBi fiber. As polarization coupling can be neglected in very short lengths of polarization preserving fibers, a two grating model is employed, each one corresponding to the effective refractive index for each polarization of the fundamental mode in an optical fiber.

Figure 6 shows the result of the simulation for small gratings, each one with length of 1 mm, and strong coupling. It can be seen that both spectra overlap in a single reflection band.

Using the same design parameters, but increasing the grating length to 10mm it is possible to see that the optical spectrum corresponding to each polarization is now well resolved from the other, as shown in Fig. 7.

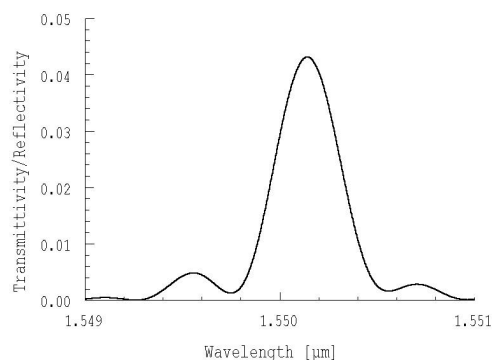

Figure 6 – Simulated spectra of HiBi FOBG with length = 1 mm.

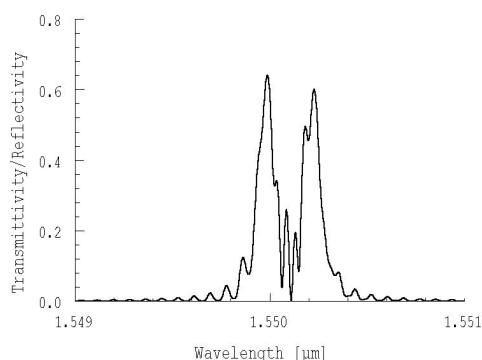

Figure 7 – Simulated spectra of HiBi FOBG with length = 10 mm.

From the numerical simulation it was also possible to verify that, even for low values of the coupling constant ( $k$ ), the spectra of two short gratings is always overlapped in a single band. This leads to the conclusion that the important parameter in the optical writing set up is the length of the fringe pattern that can be obtained, in order to increase the grating length.

FOBG written in polarization preserving PANDA fibers are produced and measured. The optical spectrum presents a single, non-resolved, reflection band with typical bandwidth of 1 nm. It is possible to resolve the spectra when transversal load is applied on the fiber. Numerical simulation of the spectra indicates that gratings of longer length are required to have the spectra from each polarization well resolved under no load.

### Acknowledgements

This work is supported by CNPq, CAPES, FAPESP and CAPES/ICCTI project 58/00. We thank Dr. Paula Gouveia (Corning, Inc.) and Fujikura, Inc. for providing some of the fibers used in this work.

### References

- [1] UDD, E., SCHULZ, W. L. and SEIM, J., “Multi-axis fiber grating strain sensor applications for structural monitoring and process control”, Proc. SPIE vol. 3538, pp. 206-214, 1999.
- [2] LAWRENCE, C. M., NELSON, D. V. and UDD, E., “Measurement of transverse strains with fiber Bragg gratings”, Proc. SPIE vol. 3042, pp. 218-228, 1997.
- [3] KASHYAP R, “Fiber Bragg Grating”, Academic Press, New York, 1999.
- [4] BARBOSA, C. L. , RABELO, R. C., LISBÔA, O., ALMEIDA, V. R., HATTORI, H. T., CAZO, R. M., “Técnica da Máscara de Fase para a Fabricação de Grades de Bragg em Fibras Ópticas”, Anais IX Simpósio Brasileiro de Microondas e Optoeletrônica, 2000.